

Series M

SOLENOID VALVES

NORMALLY CLOSED

PRODUCT DATA

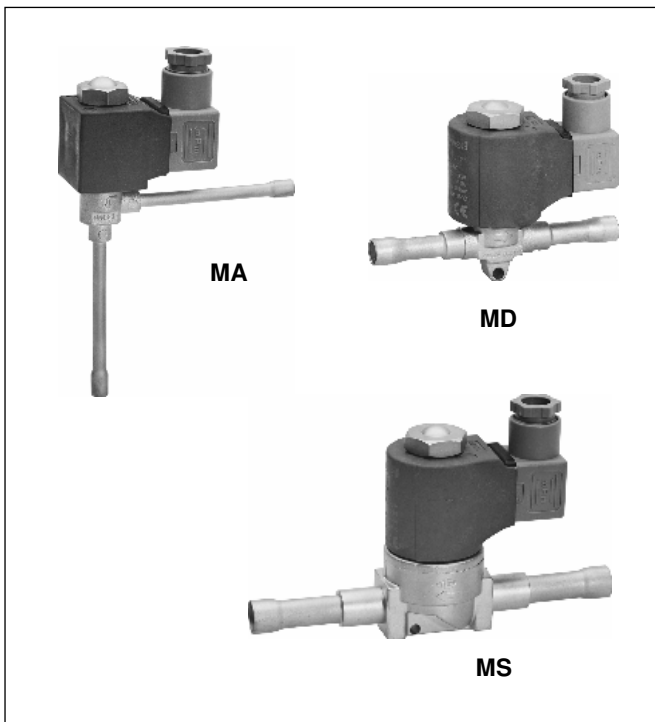

Features

- **MA:** direct operated, angle construction
- **MD:** direct operated, two way construction
- **MS:** pilot operated, two way construction
- Normally closed
- Hermetic construction
- Low pressure drop
- High performance
- **Direct operated:** no minimum pressure differential required to open the valve
- **Pilot operated:** minimum pressure differential of 0.05 bar required to open the valve
- Solder and flare connections
- Coils for AC and DC
- Refrigerants: all CFC, HCFC, HFC, not for ammonia

Specification

Nominal capacity	see tables on page 2
Maximum pressure PS	35 bar
Maximum test pressure	50 bar
Min. pressure differential	MA, MD: 0 bar MS: 0.05 bar
Max. pressure differential	MS: 2 bar
Max. opening pressure differential MOPD	AC-coil: MA, MD: 25bar MS: 30 bar DC-coil: MA, MD: 21bar MS: 21 bar
Max. medium temperature	125 °C
Min. medium temperature	-45 °C
Max. ambient temperature	80 °C
Min. ambient temperature	-40 °C
Number of operating cycles	> 1,5 million
Standard coil voltages	AC: 230V, 110V, 24V DC: 230V, 24V further voltages on request
Voltage tolerance	AC: ±10% DC: +10%, -5%

Application

Solenoid valves series M are used in general refrigeration and for original equipment to cut off/activate the refrigerant flow in a refrigerating plant.

The solenoid valves can be installed in the liquid line, hot gas line and suction line of a refrigerating unit.

Materials

Body	brass, stainless steel
Seal material	PTFE
Connection tubes	solder: copper flare: brass
Coil	copper, steel, Crastin

Nominal Capacity QN (kW)

Type	kv-value (m ³ /h)	Liquid				Hot gas				Suction gas			
		R134a	R22	R407C	R404A R507	R134a	R22	R407C	R404A R507	R134a	R22	R407C	R404A R507
Direct operated													
MA 062	0.17	5.21	5.62	5.39	3.87	1.14	1.47	1.45	1.29	-	-	-	-
MD 062	0.17	5.21	5.62	5.39	3.87	1.14	1.47	1.45	1.29	-	-	-	-
MD 102	0.22	6.74	7.27	6.98	5.01	1.48	1.90	1.88	1.67	-	-	-	-
MD 103	0.23	7.05	7.61	7.29	5.24	1.54	1.99	1.96	1.75	-	-	-	-
Pilot operated													
MS 103	0.9	27.6	29.8	28.5	20.5	6.04	7.78	7.67	6.83	1.54	2.06	1.92	1.80
MS 104	0.9	27.6	29.8	28.5	20.5	6.04	7.78	7.67	6.83	1.54	2.06	1.92	1.80
MS 124	1.6	49.0	52.9	50.7	36.4	10.7	13.8	13.6	12.1	2.74	3.66	3.42	3.19
MS 125	1.6	49.0	52.9	50.7	36.4	10.7	13.8	13.6	12.1	2.74	3.66	3.42	3.19
MS 165	2	61.3	66.1	63.4	45.5	13.4	17.3	17.1	15.2	3.42	4.57	4.27	3.99
MS 167	2	61.3	66.1	63.4	45.5	13.4	17.3	17.1	15.2	3.42	4.57	4.27	3.99
MS 227	4	123	132	127	91.1	26.8	34.6	34.1	30.4	6.85	9.14	8.54	7.98

The nominal capacity QN is based on the following conditions

Medium	Evaporating temperature to (°C)	Condensing temperature tc (°C)	Subcooling Δtc2u (K)	Hot gas temperature th (°C)	Pressure loss across valve Δp (bar)
Liquid	-10	25	1	-	0.4
Hot gas	-10	25	1	25 °C	1
Suction gas	-10	25	1	-	0.15

Valve selection for other operating conditions see the following tables or consult the Honeywell software

Valve size calculation for the liquid line

Refrigeration capacity Q_0 , multiplied with correcting factor f_{TF} , multiplied with correcting factor $f_{\Delta PF}$ results in the required nominal capacity Q_N .

$$Q_N = Q_0 \times f_{TF} \times f_{\Delta PF}$$

- Q_N nominal capacity (according to table on page 2)
- Q_0 refrigeration capacity
- f_{TF} correcting factor for evaporating and liquid temperature
- $f_{\Delta PF}$ correcting factor for pressure loss across the valve

Correcting factor f_{TF} for the change of capacity according to the operating temperatures

t_L (°C)	Evaporating temperature to (°C)																							
	R134a						R22						R407C						R404A, R507					
	+10	±0	-10	-20	-30	-40	+10	±0	-10	-20	-30	-40	+10	±0	-10	-20	-30	+10	±0	-10	-20	-30	-40	
0	-	-	0.80	0.83	0.85	0.88	-	-	0.82	0.83	0.85	0.88	-	-	0.80	0.80	0.80	-	-	0.73	0.76	0.79	0.83	
+5	-	-	0.83	0.86	0.89	0.93	-	-	0.85	0.87	0.89	0.91	-	0.80	0.80	0.80	0.90	-	-	0.77	0.8	0.84	0.88	
+10	-	0.84	0.87	0.91	0.94	0.97	-	0.86	0.88	0.90	0.92	0.95	-	0.80	0.90	0.90	0.90	-	0.79	0.82	0.85	0.89	0.94	
+15	-	0.88	0.91	0.94	0.98	1.02	-	0.90	0.92	0.94	0.96	0.99	0.90	0.90	0.90	0.90	1.00	-	0.84	0.87	0.91	0.95	1.00	
+20	0.89	0.92	0.95	0.99	1.03	1.08	0.92	0.94	0.96	0.98	1.00	1.03	0.90	0.90	0.90	1.00	1.00	0.86	0.89	0.93	0.97	1.02	1.08	
+25	0.94	0.96	1.00	1.05	1.09	1.14	0.96	0.98	1.00	1.03	1.05	1.09	0.90	1.00	1.00	1.00	1.10	0.92	0.96	1.05	1.05	1.11	1.18	
+30	0.99	1.02	1.06	1.12	1.16	1.22	1.01	1.02	1.05	1.08	1.10	1.14	1.00	1.00	1.00	1.10	1.20	0.99	1.03	1.08	1.14	1.21	1.29	
+35	1.04	1.08	1.12	1.18	1.24	1.30	1.05	1.07	1.10	1.13	1.16	1.20	1.10	1.10	1.10	1.20	1.20	1.08	1.13	1.19	1.26	1.34	1.44	
+40	1.10	1.14	1.19	1.26	1.32	1.39	1.10	1.12	1.15	1.19	1.22	1.26	1.10	1.20	1.20	1.30	1.30	1.18	1.24	1.32	1.40	1.50	1.63	
+45	1.18	1.22	1.28	1.35	1.42	1.50	1.17	1.19	1.22	1.26	1.29	1.34	1.20	1.30	1.30	1.40	1.40	1.32	1.39	1.48	1.59	1.72	1.88	
+50	1.25	1.24	1.37	1.45	1.53	1.62	1.23	1.26	1.29	1.33	1.37	1.42	1.30	1.40	1.40	1.50	1.60	1.50	1.59	1.7	1.85	2.02	2.23	
+55	1.35	1.41	1.48	1.58	1.67	1.78	1.30	1.33	1.37	1.42	1.46	1.52	1.40	1.50	1.60	1.70	1.80	1.74	1.87	2.02	2.22	2.47	2.79	
+60	1.46	1.55	1.61	1.73	1.84	1.97	1.38	1.41	1.46	1.51	1.56	1.63	-	-	-	-	-	-	-	-	-	-	-	

* Temperature of liquid refrigerant at valve inlet.

Correcting factor $f_{\Delta PF}$ for the change of capacity according to the chosen pressure loss across the valve

Pressure loss across valve Δp (bar)	0.05	0.10	0.15	0.20	0.25	0.30	0.35	0.40	0.45	0.50	0.55	0.60	0.65	0.70
Correcting factor $f_{\Delta PF}$	2.83	2.00	1.63	1.41	1.26	1.15	1.07	1.00	0.94	0.89	0.85	0.82	0.78	0.76

Valve capacity for the hot gas line

Type	Pressure loss across valve Δp (bar)	Capacity (kW)*																	
		Condensing temperature t_c (°C)																	
		R134a					R22					R407C				R404A, R507			
		+25	+30	+40	+50	+60	+25	+30	+40	+50	+60	+25	+30	+40	+50	+25	+30	+40	+50
Direct operated																			
MA 062 MD 062	0.2	0.54	0.55	0.57	0.58	0.57	0.68	0.70	0.74	0.76	0.78	0.62	0.65	0.68	0.70	0.60	0.60	0.58	0.53
	0.5	0.83	0.86	0.89	0.90	0.89	1.06	1.10	1.15	1.19	1.22	0.98	1.02	1.08	1.11	0.93	0.93	0.90	0.83
	1.0	1.12	1.17	1.23	1.25	1.24	1.46	1.51	1.60	1.67	1.70	1.39	1.44	1.52	1.57	1.29	1.29	1.26	1.16
	1.5	1.31	1.38	1.47	1.50	1.50	1.74	1.81	1.93	2.01	2.06	1.71	1.77	1.87	1.93	1.54	1.55	1.52	1.41
	2.0	1.44	1.52	1.64	1.70	1.70	1.94	2.04	2.19	2.29	2.34	1.96	2.04	2.15	2.22	-	-	-	-
MD 102	0.2	0.69	0.72	0.75	0.75	0.73	0.77	0.91	0.96	0.99	1.00	0.81	0.83	0.88	0.91	0.77	0.77	0.74	0.68
	0.5	1.07	1.11	1.15	1.17	1.16	1.37	1.42	1.49	1.55	1.58	1.27	1.32	1.39	1.44	1.20	1.20	1.17	1.07
	1.0	1.44	1.51	1.60	1.62	1.61	1.89	1.96	2.08	2.15	2.20	1.80	1.87	1.97	2.04	1.66	1.67	1.63	1.50
	1.5	1.69	1.78	1.89	1.94	1.93	2.25	2.34	2.50	2.60	2.66	2.21	2.29	2.41	2.49	1.99	2.00	1.96	1.82
	2.0	1.86	1.97	2.12	2.20	2.20	2.52	2.64	2.83	2.97	3.03	2.55	2.64	2.79	2.88	-	-	-	-
MD 103	0.2	0.72	0.75	0.78	0.78	0.77	0.80	0.95	1.00	1.03	1.05	0.84	0.87	0.92	0.95	0.80	0.80	0.78	0.71
	0.5	1.12	1.16	1.21	1.22	1.21	1.43	1.48	1.56	1.62	1.65	1.33	1.38	1.46	1.50	1.26	1.26	1.22	1.12
	1.0	1.51	1.58	1.67	1.69	1.68	1.98	2.05	2.17	2.25	2.30	1.88	1.95	2.06	2.13	1.74	1.74	1.70	1.57
	1.5	1.77	1.86	1.98	2.03	2.02	2.35	2.45	2.61	2.72	2.78	2.31	2.39	2.52	2.61	2.08	2.09	2.05	1.90
	2.0	1.94	2.06	2.22	2.30	2.30	2.64	2.76	2.96	3.10	3.17	2.66	2.76	2.91	3.01	-	-	-	-
Pilot operated																			
MS 103 MS 104	0.2	2.83	2.93	3.04	3.06	3.02	4.20	4.33	4.55	4.70	4.79	3.60	3.71	3.90	4.03	3.09	3.09	3.00	2.74
	0.5	4.37	4.53	4.73	4.78	4.72	6.55	6.76	7.13	7.38	7.52	5.61	5.79	6.11	6.33	4.89	4.89	4.80	4.37
	1.0	5.93	6.19	6.52	6.63	6.57	9.02	9.35	9.91	10.3	10.5	7.73	8.01	8.49	8.83	6.77	6.86	6.69	6.09
	1.5	6.93	7.29	7.77	7.95	7.92	10.8	11.2	11.9	12.4	12.7	9.26	9.60	10.2	10.6	8.14	8.14	8.06	7.37
	2.0	7.60	8.07	8.66	9.00	9.00	12.1	12.6	13.5	14.2	14.5	10.4	10.8	11.6	12.2	-	-	-	-
MS 124 MS 125	0.2	5.04	5.21	5.40	5.44	5.36	6.40	6.60	6.94	7.17	7.30	5.86	6.07	6.41	6.62	5.60	5.60	5.44	4.96
	0.5	7.77	8.07	8.40	8.50	8.39	9.97	10.3	10.9	11.2	11.5	9.27	9.6	10.1	10.5	8.76	8.76	8.52	7.80
	1.0	10.5	11.0	11.6	11.8	11.7	13.7	14.3	15.1	15.7	16.0	13.1	13.6	14.3	14.8	12.1	12.1	11.8	10.9
	1.5	12.3	13.0	13.8	14.1	14.1	16.4	17.1	18.2	19.0	19.4	16.1	16.6	17.6	18.1	14.5	14.6	14.3	13.2
	2.0	13.5	14.3	15.5	16.0	16.0	18.4	19.2	20.6	21.6	22.1	18.5	19.2	20.3	20.9	-	-	-	-
MS 165 MS 167	0.2	6.29	6.51	6.76	6.80	6.70	8.00	8.25	8.68	8.96	9.12	7.33	7.59	8.01	8.28	7.00	7.00	6.80	6.20
	0.5	9.72	10.1	10.5	10.6	10.5	12.5	12.9	13.6	14.1	14.3	11.6	12.0	12.7	13.1	10.9	10.9	10.6	9.70
	1.0	13.2	13.7	14.5	14.7	14.6	17.2	17.8	18.9	19.6	20.0	16.4	17.0	17.9	18.5	15.1	15.2	14.8	13.6
	1.5	15.4	16.2	17.2	17.7	17.6	20.5	21.3	22.7	23.7	24.2	20.1	20.8	22.0	22.7	18.1	18.2	17.9	16.5
	2.0	16.9	17.9	19.3	20.0	20.0	23.0	24.0	25.7	27.0	27.6	23.2	24.0	25.3	26.2	-	-	-	-
MS 227	0.2	12.6	13.0	13.5	13.6	13.4	16.0	16.5	17.4	17.9	18.2	14.7	15.2	16.0	16.6	14.0	14.0	13.6	12.4
	0.5	19.4	20.1	21.0	21.2	21.0	24.9	25.8	27.1	28.1	28.6	23.2	24.0	25.3	26.2	21.9	21.9	21.3	19.5
	1.0	26.3	27.5	29.0	29.5	29.2	34.4	35.6	37.8	39.2	40.0	32.8	33.9	35.8	37.0	30.3	30.4	29.7	27.3
	1.5	30.8	32.4	34.5	35.3	35.2	41.0	42.6	45.4	47.4	48.4	40.1	41.6	43.9	45.3	36.3	36.5	35.8	33.1
	2.0	33.8	35.9	38.7	39.9	40.0	45.9	48.0	51.5	53.9	55.2	46.3	48.0	50.7	52.4	-	-	-	-

* Capacities are based on evaporating temperature $t_0 = -10$ °C, hot gas temperature $t_H = +25$ °C and 1 K subcooled refrigerant.

If the hot gas temperature is changed by ± 10 °C the valve capacity changes (inversely proportional) by $\pm 2,5$ %.

With other evaporating temperatures to the capacities above should be multiplied by the following correcting factors:

t_0 (°C)	-50	-40	-30	-20	-10	± 0	+10
R134a	-	0.85	0.90	0.95	1.00	1.05	1.09
R22	0.88	0.91	0.95	0.97	1.00	1.03	1.05
R407C	0.83	0.88	0.92	0.95	1.00	1.01	1.06
R404A, R507	0.75	0.81	0.88	0.13	1.00	1.05	-

Valve size calculation for the suction line

Refrigeration capacity Q_0 , multiplied with correcting factor f_{TS} , multiplied with correcting factor $f_{\Delta PS}$ results in the required nominal capacity Q_N .

$$Q_N = Q_0 \times f_{TS} \times f_{\Delta PS}$$

Q_N nominal capacity (according to table on page 2)

Q_0 refrigeration capacity

f_{TS} correcting factor for evaporating and liquid temperature

$f_{\Delta PS}$ correcting factor for pressure loss across the valve

Correcting factor f_{TS} for the change of capacity according to the operating temperatures

Evaporating temperature t_0 (°C)	Condensating temperature t_c (°C)				
	+60	+50	+40	+30	+20
	For refrigerant R134a, R22, R407C				
+10	0.98	0.86	0.78	0.71	0.66
±0	1.19	1.05	0.95	0.86	0.79
-10	1.48	1.29	1.16	1.05	0.96
-20	1.88	1.62	1.44	1.31	1.19
-30	2.42	2.08	1.83	1.65	1.59
-40	3.20	2.71	2.37	2.13	1.92
For refrigerant R404A, R507					
+10	-	1.14	0.82	0.71	0.63
±0	-	1.24	1.01	0.87	0.77
-10	-	1.57	1.26	1.07	0.94
-20	-	2.02	1.60	1.35	1.17
-30	-	2.67	2.07	1.72	1.49
-40	-	3.62	2.74	2.25	1.93

Correcting factor $f_{\Delta PS}$ for the change of capacity according to the chosen pressure loss across the valve

Pressure loss across valve Δp (bar)	0.05	0.075	0.10	0.15	0.20	0.30	0.40	0.50	0.60
Correcting factor $f_{\Delta PS}$	1.73	1.41	1.22	1.00	0.87	0.71	0.61	0.55	0.50

Type Code / Order Information

1. Solenoid Valve

	M		S		16		5		S		230 V AC
Series											
Type: A = direct operated, angle D = direct operated S = pilot operated											
Valve size											
Connection size in 1/8"											
() = flare connection MMS = solder, metric S = solder, inch											
Voltage () = without coil											

2. Solenoid Coil

Type of coil, capacity	For Solenoid Valve	Voltage, frequency	Voltage tolerance
MC 062, 8 W	MA 062(S)(MMS) MD 062(S)(MMS)	230 V, 50/60 Hz 110 V, 50/60 Hz 24 V, 50/60 Hz	±10 %
MC 102-227, 13 W	MD 102(S)(MMS) MD 103(S)(MMS) MS 103-227(S)(MMS)	230 V, 50/60 Hz 110 V, 50/60 Hz 24 V, 50/60 Hz	±10 %
MC 102-227, 20 W	MD 102(S)(MMS) MD 103(S)(MMS) MS 103-227(S)(MMS)	24 V DC 230 V DC	+10 % -5 %

International protection rating IP65, coil incl. e.l.c.b.-protected plug to DIN 43650 with cable gland; conduit thread PG11.

Dimensions and Weights

Type	Connections (E)	For tube diameter	Dimensions (mm)				Weight (kg)	
			A	B	C	D	without coil 230 V AC	with coil 230 V AC
Direct operated								
MA 062MMS	6 mm ODF	6 mm	88	88	142	47	0.15	0.30
MA 062S	1/4" ODF	1/4"	88	88	142	47	0.15	0.30
MD 062	7/16" UNF	6 mm, 1/4"	65	17	57	47	0.19	0.33
MD 062MMS	6 mm ODF	6 mm	112	17	57	47	0.17	0.31
MD 062S	1/4" ODF	1/4"	112	17	57	47	0.17	0.31
MD 102	7/16" UNF	6 mm, 1/4"	68	19	64	54	0.19	0.33
MD 102MMS	6 mm ODF	6 mm	118	19	64	54	0.17	0.31
MD 102S	1/4" ODF	1/4"	118	19	64	54	0.17	0.31
MD 103	5/8" UNF	10 mm, 3/8"	71	19	64	54	0.28	0.52
MD 103MMS	10 mm ODF	10 mm	118	19	64	54	0.25	0.49
MD 103S	3/8" ODF	3/8"	118	19	64	54	0.25	0.49
Pilot operated								
MS 103	5/8" UNF	10 mm, 3/8"	84	12	79	54	0.51	0.75
MS 103MMS	10 mm ODF	10 mm	159	12	79	54	0.55	0.79
MS 103S	3/8" ODF	3/8"	159	12	79	54	0.55	0.79
MS 104 MMS	12 mm ODF	12 mm	159	12	79	54	0.56	-
MS 104S	1/2" ODF	1/2"	159	12	79	54	0.56	-
MS 124	3/4" UNF	12 mm, 1/2"	91	12	79	54	0.54	0.77
MS 124MMS	12 mm ODF	12 mm	159	12	79	54	0.56	0.79
MS 124S	1/2" ODF	1/2"	159	12	79	54	0.56	0.79
MS 125S	16 mm, 5/8" ODF	16 mm, 5/8"	159	12	79	54	0.56	-
MS 165	7/8" UNF	16 mm, 5/8"	97	12	79	54	0.57	0.80
MS 165S	16 mm, 5/8" ODF	16 mm, 5/8"	159	12	79	54	0.59	0.82
MS 167S	22 mm, 7/8" ODF	22 mm, 7/8"	173	12	79	54	0.59	-
MS 227S	22 mm, 7/8" ODF	22 mm, 7/8"	262	22	88	54	1.45	1.65

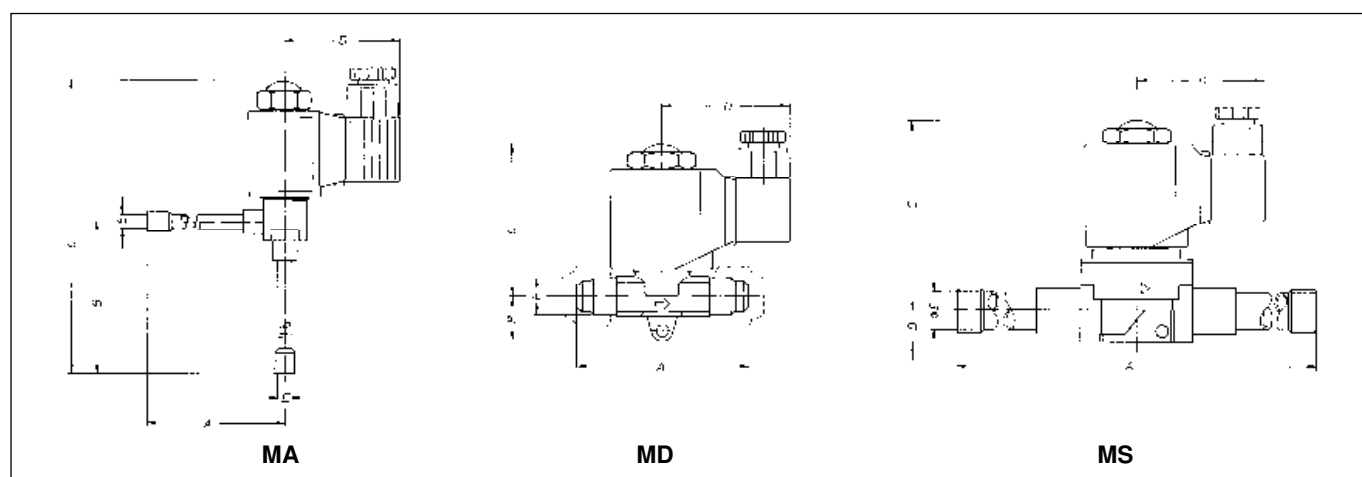

Installation

- Position of plunger tube should be from upright to horizontal position.
- Arrow on valve body must correspond with flow direction.
- Keep 45 mm distance clear above the valve for assembly/disassembly of coil.
- Fit solenoid valve so that it is drip proof.
- **Solder valves:**
 - m Remove cap nut, coil and gaskets before soldering
 - m Max. temperature of valve body: 120 °C.
 - m When soldering, always point flame away from valve body
 - m When assembling after soldering, fit the coil's top and bottom seal rings.
- **Flare valves:**
 - m When tightening flare nuts grip at wrench flats on the valve body provided for this purposes
 - m Do not use coil and plunger tube as lever (thin-walled plunger tube).
 - m When installing direct operated valves with 20 W DC coil, the flare nut must be tightened in that way that one flat of the nut is in parallel with the lower surface of the coil.
- Voltage of coil and network must correspond.
- The flat spade terminals is the earth connection. The protective conductor must also be connected at the plant.
- Do not energize the coil before assembling on the valve body.
- All gaskets must be fitted carefully in order to achieve protection to IP65.
- Tighten fixing screw of connector.
- Constructive modifications at the valve are not allowed.

Honeywell

Automation and Control Solutions

Honeywell GmbH
Hardhofweg
74821 Mosbach/Germany
Phone: +49 (0) 62 61 / 81-475
Fax: +49 (0) 62 61 / 81-461
E-Mail: cooling.mosbach@honeywell.com
www.honeywell-cooling.com

Manufactured for and on behalf of the
Environment and Combustion Controls
Division of Honeywell Technologies Sàrl,
Ecublens, Route du Bois 37, Switzerland
by its authorised representative Honeywell GmbH